

Ortho Box® Drawer Storage System

CONTENTS

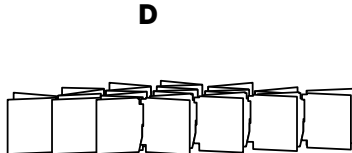
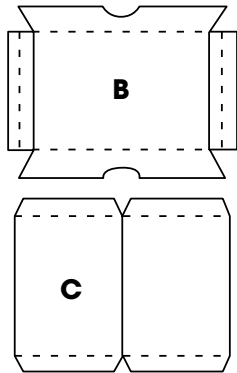
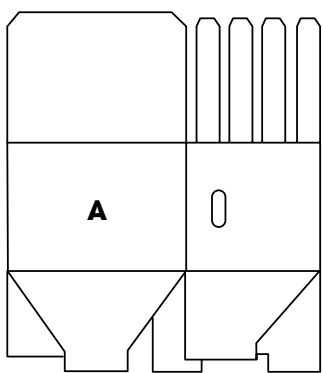

- A** Box (1)
- B** Trays (4)
- C** Shelves (3)
- D** Long Dividers (3 each per tray)
- E** Short Dividers (4 each per tray)

CONSTRUCTING THE SHELVES

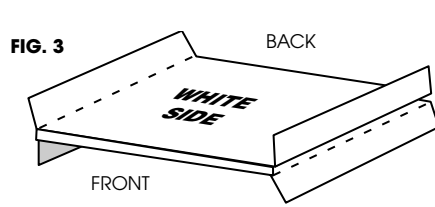
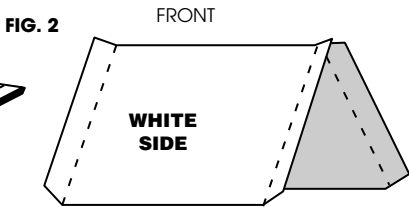
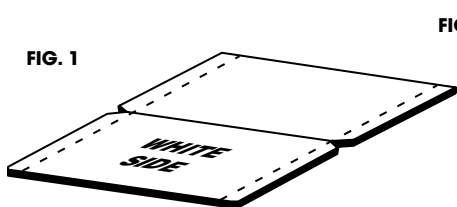

Fig. 1: Shelf flat.

Fig. 2: Fold center and side "wing" perforations.

Fig. 3: Shelf top and bottom flat with "wings" perpendicular to shelf.

CONSTRUCTING THE BOX

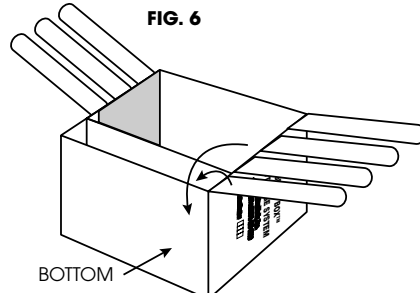
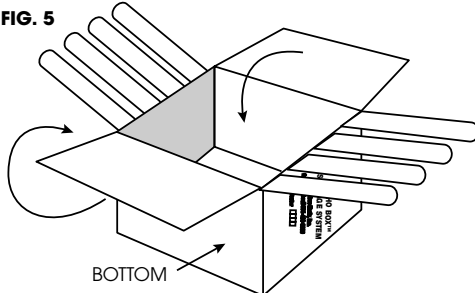
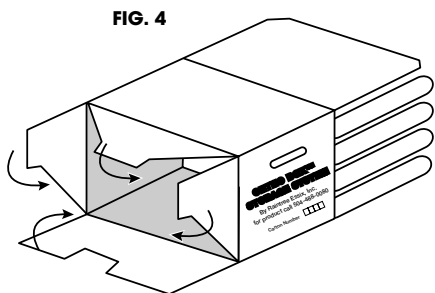

Fig. 4: Square up box; lock flaps A, B, C & D into place.

Fig. 5: Fold flaps E & F inside box to lock into place.

Fig. 6: Place first constructed shelf in box; fold flap 1 & 2 over shelf wing to lock into place; continue with rest of shelves and flaps.

FORMING THE TRAYS

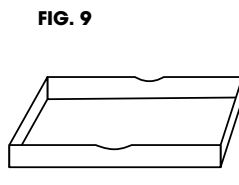
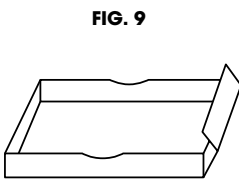
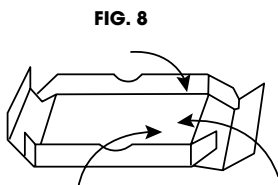
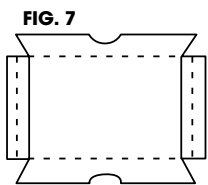

Fig. 7: Select 1 of 4 trays (piece B).

Fig. 8: Fold up long sides of tray; fold short flaps at each end.

Fig. 9: Fold notched flaps over short flaps; insert notches into base.

Fig. 10: Repeat steps in Fig. 5 at other end.

PLACING TRAY DIVIDERS

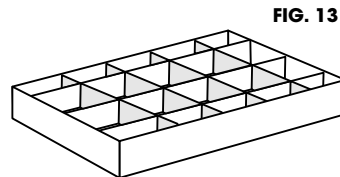
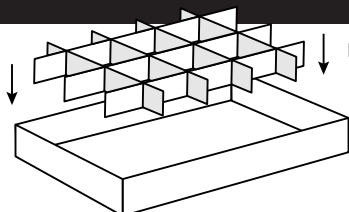
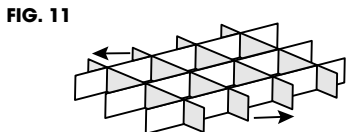

Fig. 11: Pull ends of dividers (C) in opposite directions until grid opens up.

Fig. 12: Insert dividers into tray.

Fig. 13: Complete tray should be divided into 20 compartments.

INSERT TRAYS INTO ORTHO BOX®

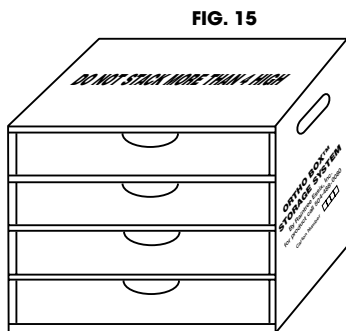
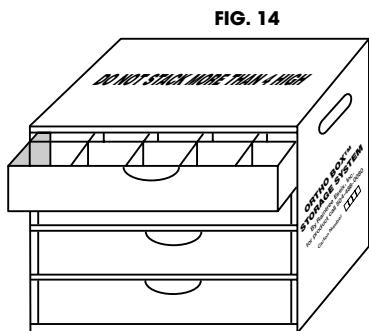

Fig. 14: Slide the four completed trays right side up onto shelves.

Fig. 15: Completed Ortho Box® holds 4 trays of 20 compartments